

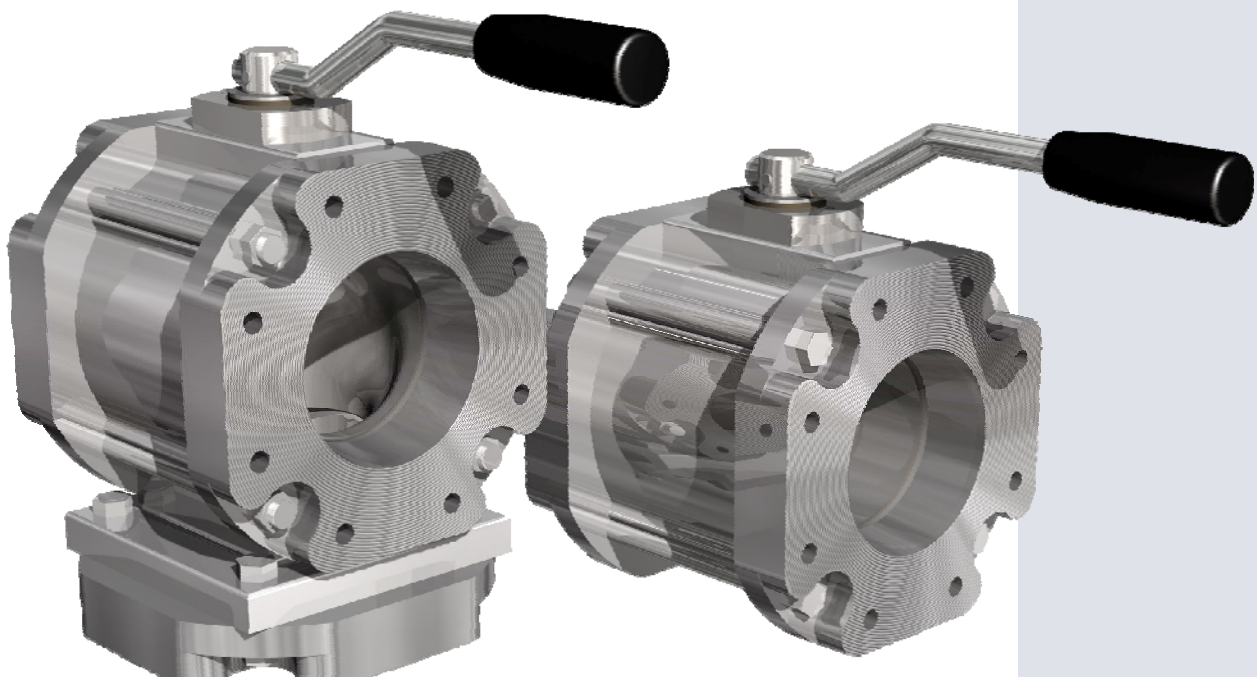

FFBall Valves

Full Flow Ball Valves



Service Instruction

Straight / 2-way



Quality, Health, Safety and Environment Policy

Our objectives are simple – no accidents, no occupational illness or work related accidents, no negative environmental impact and optimizing and continuously improving customer satisfaction wherever we operate.

Mariestad, February 28 2008

A handwritten signature in blue ink, appearing to read "Tony Mann".
Tony Mann

What does this mean?

In our daily work to develop, sell, deliver and maintain our products this means to act as soon as we recognize a risk for:

- Delivery of products with insufficient technical quality
- Giving incorrect information
- Not complying with laws and regulations concerning our operation
- Causing negative environmental impact
- Causing occupational illness or accidents
- Not be able to keep promises on delivery terms (product and information)

To act, here means to point out the risk and to make sure we take a balanced decision to prevent what is undesired.

(This policy includes all that is traditionally covered in separate policies for quality, health, safety and environment)

Ball Valve 3" - Straight

Material: Al

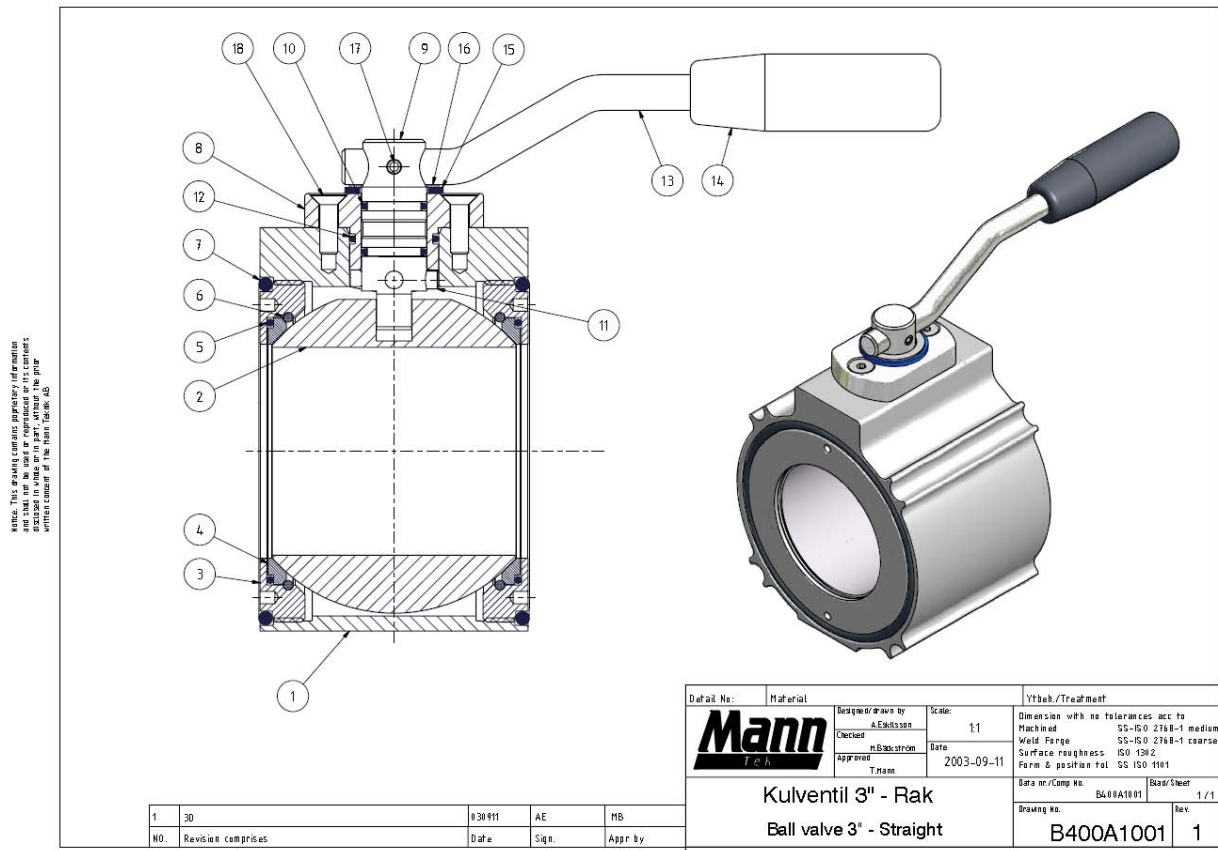

Needed for service: Spare part kit (see page 4)
 Hexagon wrench, Torque wrench, Hammer, Pointed device, O-Ring needle, Assembly tools (see page 5)

Perform a service: If leaking
 Every year
 Change of media



Please note!

Make sure that you are using the right type of O-rings and seals for the media you are using. We are using a standard grease Mann no F1 for standard media, by special media please contact us.

Maintenance and service instruction



Always depressurise the system and rinse off the parts before beginning any maintenance work. Use protective goggles. Do not handle O-ring seals if the material appears charred, gummy or sticky.



Use tweezers and wear neoprene or PVC gloves. Do not touch adjacent parts with unprotected hands. Rinse off the parts once again before starting the “daily inspection”

Daily inspection

1. Inspect the coupling surface for cleanliness and corrosion.
2. Inspect the O-ring between the housing and the connection flanges for serviceability and correct seating in the groove as far as possible.
3. Inspect the handle and the ball for free rotation.
4. Inspect the ball valve for faultlessness and external signs of seizure.

Three-month inspection

1. Exterior cleaning of the coupling with a neutral cleanser.
2. Careful “daily inspection” of cleaned units.

Once a year

1. Exchange sealing and washer at least once a year.
2. Refill grease where needed
3. Replace worn or damaged components. Repair procedures are straightforward and no special tools are required.

Check the state of the connection surface and verify that it is clean before proceeding with the connection.

Check for correct operation of the valve. Switch the unit(s) several times.

Use only original Mann Teknik spare parts for maintenance.

Support ring kit (S-BSRX-yy)

Handle kit (S-BSHX-yy)

X and yy means the size and the material key according to the product catalogue. You will find it also as the 2nd to 8th/9th sign in the serial number (eg. BX00A10yy).

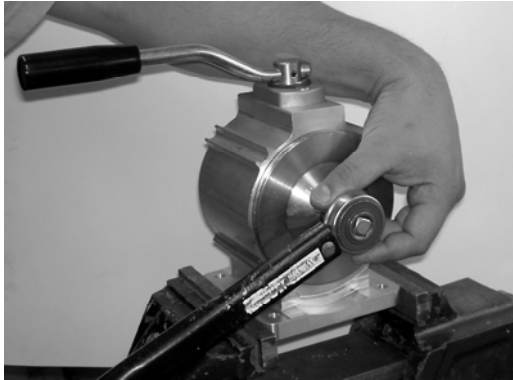

Unscrew the support ring on one side

Tool: Assembly tool 2" VB2-1646

Assembly tool 3" VB3-1650

Assembly tool 4" VB4-1654



Unscrew 2 screws to loose the handle

Tool: Hex socket wrench

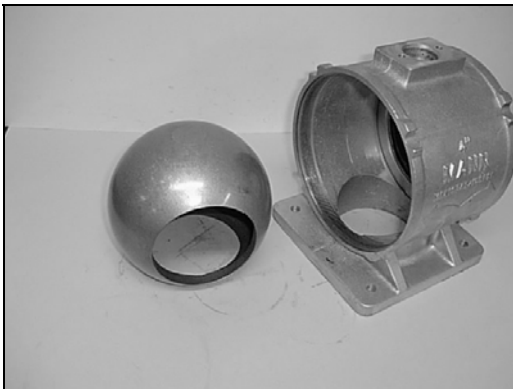

Take out the ball from the body

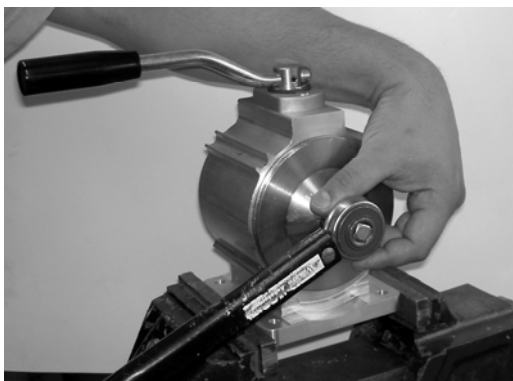

Unscrew the other support ring from the body

Tool: Assembly tool 2" TOOL 1646

Assembly tool 3" TOOL 1650

Assembly tool 4" TOOL 1654



Take out the pin from the handle

Tools: Hammer, pointed device



Remove the handle from the spindle

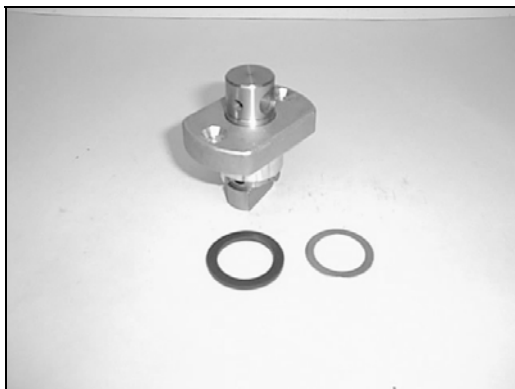

Remove the seal and the metal plate



Remove the spindle from the spindle bushing

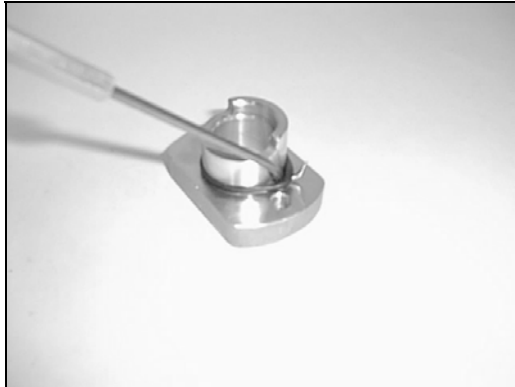

Change the O-ring on the spindle bushing to a new one. Use grease on the O-ring. Make sure the O-ring doesn't get twisted when mounting.

Tools: O-ring needle

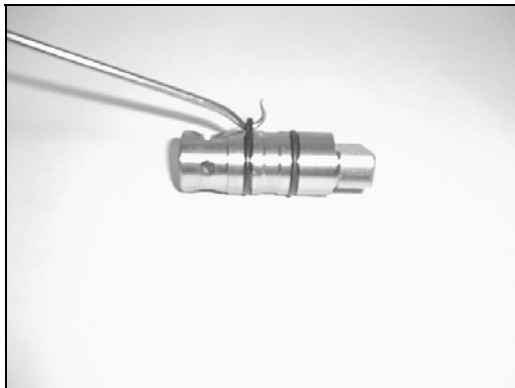

Change the two O-rings on the spindle. Use grease on the O-rings. Make sure the O-rings don't get twisted when mounting.

Tools: O-ring needle



Mount together the spindle and spindle bushing, make sure that the pin on the spindle gets into the groove on the spindle bushing.

2-ways has two pins, both should be in the groove.

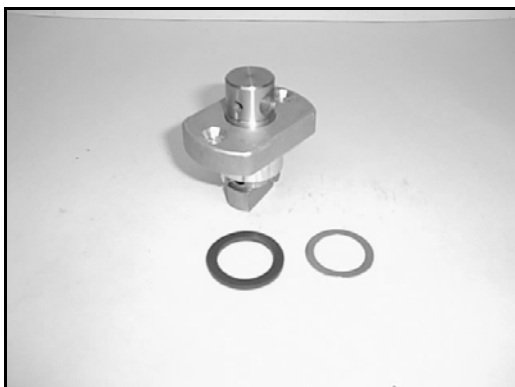

Take up a new seal and a new metal plate



Start to mount the seal and then the metal plate



Mount the handle into the spindle, make sure that the hole for the stop pin is open



Wrap the stop pin into the hole

Tools: Hammer, pointed device



Change the two end covers to new ones



Use grease on the black Teflon packing and the threads on the both end covers

Grease: Mann Tek no F1

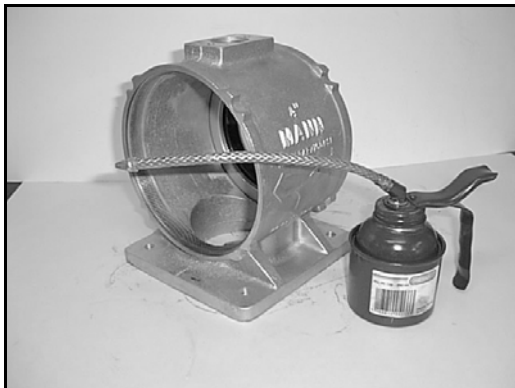

Use also grease on the threads in the body.

Grease: Mann Tek no F1

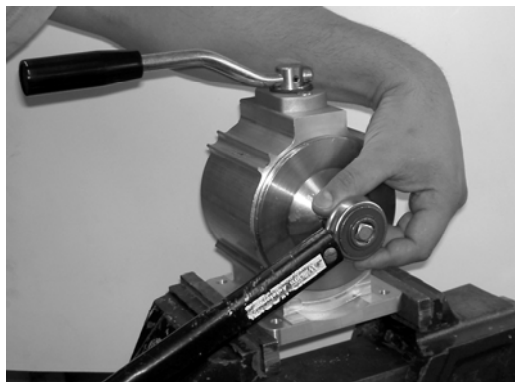

Screw on one of the end covers, tighten until the end cover comes in it's right position with the body

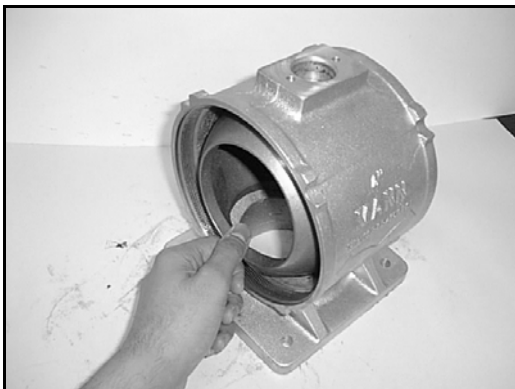

Mount the Ball; keep always the Ball open.



Make sure that you can see the groove on the ball through the hole from the handle on the body



When mounting the handle. Make sure that you keep the ball open and let the handle point to the same direction as the opening.



Screw on the handle. Use grease on the screws.

Grease: Mann Tek no F3

Tools: Hex socket wrench



Screw on the other end cover with the assembly tool, tighten both sides until they are equally recessed.

Tools: Torque wrench

2" 25 Nm

3" 30 Nm

4" 35 Nm

TEST PROCEDURE

Ball valves are tested according to following procedure:

Ball valve – Straight

Working pressure PN 10 (10 bar/150 psi)

The ball valve is closed and the first outlet facing is pressurised. The ball valve is turned 180° in the test-rig and the lever is still in closed position to test the second Teflon seal.

The ball valve is pressurised with air:

0.2 bar / 3 psi	min. 30 sec. with air under water – no bubbles
6 bar / 90 psi	min. 30 sec with air under water – no bubbles
16 bar / 235 psi	min. 30 sec with water – no leakage of water



Ball valve – 2-way

Working pressure PN 10 (10 bar/150 psi)

The ball valve is closed and the open outlet facing on the bottom side is pressurised.

The ball valve is pressurised with air:

0.2 bar / 3 psi	min. 30 sec. with air under water – no bubbles
6 bar / 90 psi	min. 30 sec with air under water – no bubbles
16 bar / 235 psi	min. 30 sec with water – no leakage of water



When the leakage test is made without leakage, the ball valve is blown dry and clean with air and is ready for use again.

In case of a leakage the ball valve must be dismantled, and the failing parts replaced. After that the complete leakage test must be made again.

Approved coupling stamps on the axis.

Number tested: 100%

Storage

Store coupling in a dry, dust free, dark place, in ambient temperature.

© Copyright 2009 Mann Teknik AB. Mann Teknik AB reserves the right to make changes at any time in prices, materials, specifications and models and to discontinue models without notice or obligations.